

GEMÜ 533 eSyStep

Motorized globe valve



Features

- Suitable for vacuum up to 20 mbar (a)
- Actuating speed max. 3 mm/s
- Open/close function or with integrated positioner
- Parameterizable via IO-Link
- Linear or modified equal-percentage control characteristics
- On-site or remote end position programming via programming input
- Various function integrated (e.g. feedback, stroke limiter, etc.)

Description

The GEMÜ 533 2/2-way globe valve is motorized. The eSyStep actuator is available as an ON/OFF actuator or as an actuator with integrated positioner. The valve spindle is sealed by a self-adjusting gland packing providing low maintenance and reliable valve spindle sealing even after a long service life. A wiper ring fitted in front of the gland packing protects the seal against contamination and damage. An integral optical and electrical position indicator is standard.

Technical specifications

- Ambient temperature*: 0 to 60 °C
- Media temperature*: -10 to 180 °C
- Operating pressure*: 0 to 15 bar
- Nominal sizes*: DN 15 to 25
- Body configurations: 2/2-way body
- Connection types: Flange
- Connection standards: ANSI | EN | JIS
- Body materials: 1.4408, investment casting | EN-GJS-400-18-LT, SG iron
- Seat seal materials: 1.4404 | PTFE | PTFE, reinforced
- Supply voltage: 24 V DC
- Actuating speed: max. 3 mm/s
- Protection class: IP 65
- Conformities: FDA | Reg. (EC) No. 1935/2004

* depending on version and/or operating parameters



Product description

Construction

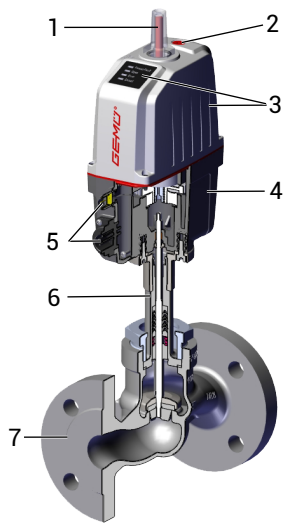

Item	Name	Materials
1	Optical position indicator	PA 12
2	Manual override	
3	Actuator top with LED display	Polyamide, 50% glass fibre
4	Actuator base	Polyamide, 50% glass fibre
5	Electrical connection	
6	Distance piece with leak detection hole	1.4305/ 1.4408
7	Valve body	1.4408, EN-GJS-400-18-LT (GGG 40.3)

GEMÜ CONEXO

The interaction of valve components that are equipped with RFID chips and an associated IT infrastructure actively increase process reliability.



Thanks to serialization, every valve and every relevant valve component such as the body, actuator or diaphragm, and even automation components, can be clearly traced and read using the CONEXO pen RFID reader. The CONEXO app, which can be installed on mobile devices, not only facilitates and improves the "installation qualification" process, but also makes the maintenance process much more transparent and easier to document. The app actively guides the maintenance technician through the maintenance schedule and directly provides him with all the information assigned to the valve, such as test reports, testing documentation and maintenance histories. The CONEXO portal acts as a central element, helping to collect, manage and process all data.

For further information on GEMÜ CONEXO please visit:

www.gemu-group.com/conexo

Ordering

GEMÜ Conexo must be ordered separately with the ordering option "CONEXO" (see order data).

In the corresponding design with CONEXO, this product has an RFID chip (1) for electronic recognition. The position of the RFID chip can be seen below.

For electronic identification purposes, each replaceable component contained in the product is equipped with an RFID chip (1). Where you can find the RFID chip differs from product to product.

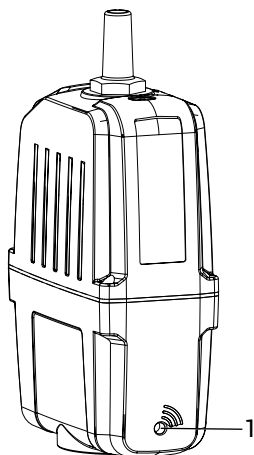

Actuator RFID chip

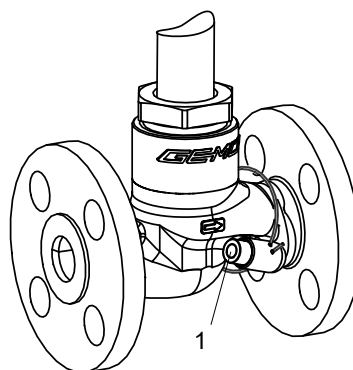

Valve body RFID chip

The CONEXO pen helps read out information stored in these RFID chips. The CONEXO app or CONEXO portal is required to view this information.

Kv value diagram

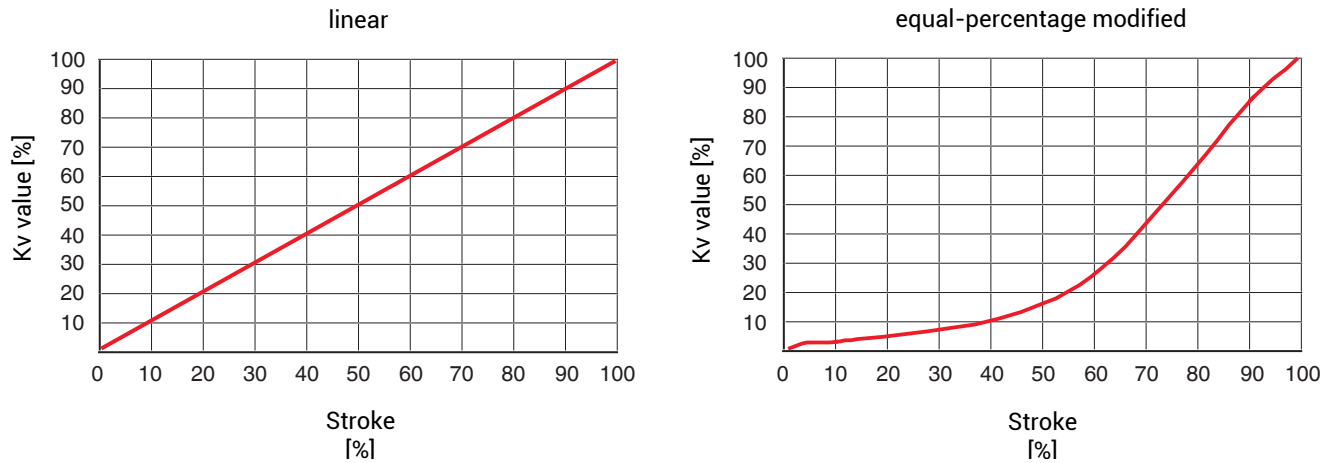

The diagram shows the approximative curve of the Kv value characteristic. The characteristic may deviate depending on valve body, nominal size, regulating cone and valve stroke.

Regulating needle / Regulating cone

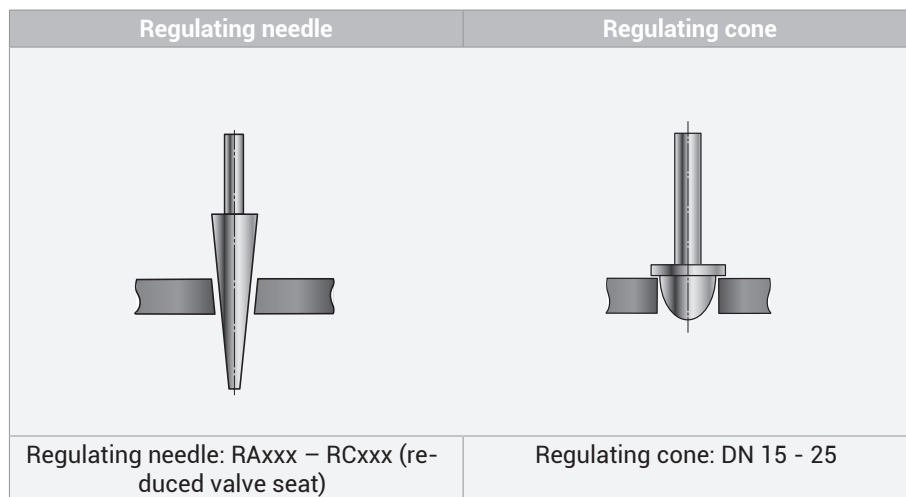

Overview of available functions

Function	Control module - OPEN/CLOSE control (code AE)	Control module - Positioner (code S0)
OPEN/CLOSE control	X	X
Positioner		X
Manual override	X	X
Optical status and position indicator	X	X
On-site initialisation	X	X
Deactivation of on-site initialisation	X	X
Initialisation via digital input	X	X
Initialisation via IO-Link	X	X
Feedback for operating mode	X	X
Activation OPEN	X	X
Activation CLOSE	X	X
Activation, analogue		X
Position feedback OPEN	X	X
Position feedback CLOSED	X	X
Position feedback analogue		X
Location function	X	X
Error output	X	X
Actuating speed adjustable	X	
Actuating force adjustable	X	X
Inversion of LED colours	X	X
Cycle counter	X	
Error counter	X	
Operating time determination	X	X
Switch point setting (tolerance)	X	X
Inversion input / output logic	X	X
Adjustable error action	X	X
Safe/On	X	X
Direction reversal		X
Open tight		X
Close tight		X
Split range		X
Stroke limiter / seal adjuster		X

Availability

Availability of valve bodies

Flange

DN	Connection types code ¹⁾				
	8	11	39		48
	Material code ²⁾				
	90	37	37	90	37
15	X	X	X	X	X
20	X	X	X	X	X
25	X	X	X	X	X

X = Standard

1) Connection type

Code 8: Flange EN 1092, PN 16, form B, face-to-face dimension FTF EN 558 series 1, ISO 5752, basic series 1

Code 11: Flange EN 1092, PN 40, form B, face-to-face dimension FTF EN 558 series 1, ISO 5752, basic series 1

Code 39: Flange ANSI Class 125/150 RF, face-to-face dimension FTF EN 558 series 1, ISO 5752, basic series 1

Code 48: Flange JIS 20K, face-to-face dimension FTF EN 558 series 10, ASME/ANSI B16.10 table 1, column 16, DN 50 drilled to JIS 10K

2) Valve body material

Code 37: 1.4408, investment casting

Code 90: EN-GJS-400-18-LT (GGG 40.3)

Product compliance

	Approved designs		
	Valve body material	Seat seal	Type of design
Food			
FDA Regulation (EC) 1935/2004 Regulation (EC) 10/2011	1.4408, investment casting (code 37)	PTFE (code 5) PTFE, glass fibre rein- forced (code 5G)	Spindle seal PTFE-PTFE (code 2013)

Order data

The order data provide an overview of standard configurations.

Please check the availability before ordering. Other configurations available on request.

Order codes

1 Type	Code
Globe valve, motorized, eSyStep	533

2 DN	Code
DN 15	15
DN 20	20
DN 25	25

3 Body configuration	Code
2/2-way body	D

4 Connection type	Code
Flange EN 1092, PN 16, form B, face-to-face dimension FTF EN 558 series 1, ISO 5752, basic series 1	8
Flange EN 1092, PN 25, form B, face-to-face dimension FTF EN 558 series 1, ISO 5752, basic series 1	10
Flange EN 1092, PN 40, form B, face-to-face dimension FTF EN 558 series 1, ISO 5752, basic series 1	11
Flange ANSI Class 125/150 RF, face-to-face dimension FTF EN 558 series 1, ISO 5752, basic series 1	39
Flange JIS 20K, face-to-face dimension FTF EN 558 series 10, ASME/ANSI B16.10 table 1, column 16, DN 50 drilled to JIS 10K	48

5 Valve body material	Code
1.4408, investment casting	37
EN-GJS-400-18-LT (GGG 40.3)	90

6 Seat seal	Code
PTFE	5
PTFE, glass fibre reinforced	5G
1.4404	10

7 Voltage/frequency	Code
24 V DC	C1

8 Control module	Code
Open/close control with additional end position feedback	AE
Open/close control with additional end position feedback, configured for emergency power module (NC)	A5
Open/close control with additional end position feedback, configured for emergency power module (NO)	A6
Positioner	S0
Positioner, configured for emergency power module (NC)	S5

8 Control module	Code
Positioner, configured for emergency power module (NO)	S6

9 Regulating cone	Code
without	
Please find the number of the optional regulating cone (R-No.) for the linear or equal-percentage modified regulating cone in the Kv value table.	R...

10 Actuator version	Code
Actuator size 0	0A

11 Type of design	Code
Without	
Spindle seal PTFE-PTFE	2013

12 CONEXO	Code
without	
Integrated RFID chip for electronic identification and traceability	C

Order example

Order option	Code	Description
1 Type	533	Globe valve, motorized, eSyStep
2 DN	20	DN 20
3 Body configuration	D	2/2-way body
4 Connection type	10	Flange EN 1092, PN 25, form B, face-to-face dimension FTF EN 558 series 1, ISO 5752, basic series 1
5 Valve body material	37	1.4408, investment casting
6 Seat seal	5	PTFE
7 Voltage/frequency	C1	24 V DC
8 Control module	S0	Positioner
9 Regulating cone	R...	Please find the number of the optional regulating cone (R-No.) for the linear or equal-percentage modified regulating cone in the Kv value table.
10 Actuator version	0A	Actuator size 0
11 Type of design		Without
12 CONEXO	C	Integrated RFID chip for electronic identification and traceability

Technical data

Medium

Working medium: Corrosive, inert, gaseous and liquid media which have no negative impact on the physical and chemical properties of the body and seal material.

Max. permissible viscosity: 600 mm²/s (cSt)
Other versions for lower/higher temperatures and higher viscosities on request.

Temperature

Media temperature: -10 to 180 °C

Ambient temperature: 0 to 60° C*

* Depending on version and/or operating parameters (see chapter duty cycle and service life)

Pressure

Operating pressure: DN 15: 15 bar
DN 20: 10 bar
DN 25: 6 bar

All pressures are gauge pressures.
For max. operating pressures the pressure / temperature correlation must be observed.
Higher operating pressures on request

Leakage rate:

Open-closed valve

Seat seal	Standard	Test procedure	Leakage rate	Test medium
Metal	DIN EN 12266-1	P12	F	Air
EPDM, FPM, PTFE	DIN EN 12266-1	P12	A	Air

Control valve

Seat seal	Standard	Test procedure	Leakage rate	Test medium
Metal	DIN EN 60534-4	1	IV	Air
PTFE, FPM, EPDM	DIN EN 60534-4	1	VI	Air

Pressure/temperature correlation:

Connection types code ¹⁾	Material code ²⁾	Max. allowable operating pressures in bar at temperature in °C			
		RT	100	150	200
8	37	16.0	16.0	14.5	13.4
10	37	25.0	25.0	22.7	21.0
11	37	40.0	40.0	36.3	33.7
39	37	19.0	16.0	14.8	13.6
8	90	16.0	16.0	15.5	14.7
39	90	17.2	16.0	14.8	13.9

1) **Connection type**

Code 8: Flange EN 1092, PN 16, form B, face-to-face dimension FTF EN 558 series 1, ISO 5752, basic series 1
Code 10: Flange EN 1092, PN 25, form B, face-to-face dimension FTF EN 558 series 1, ISO 5752, basic series 1
Code 11: Flange EN 1092, PN 40, form B, face-to-face dimension FTF EN 558 series 1, ISO 5752, basic series 1
Code 39: Flange ANSI Class 125/150 RF, face-to-face dimension FTF EN 558 series 1, ISO 5752, basic series 1
Code 48: Flange JIS 20K, face-to-face dimension FTF EN 558 series 10, ASME/ANSI B16.10 table 1, column 16, DN 50 drilled to JIS 10K

2) **Valve body material**

Code 37: 1.4408, investment casting
Code 90: EN-GJS-400-18-LT (GGG 40.3)

Kv values: **Open-closed valve**
 DN 15: 4.6 m³/h
 DN 20: 8.0 m³/h
 DN 25: 13.0 m³/h

Control valve

DN	Operating pressure [bar]	Kv value [m ³ /h]	Seat seal code	R-Number	
	0A			Linear	Equal-percentage
15	40	0.1 ¹⁾	10	RA105	RA310
	40	0.2 ¹⁾	10	RB113	RA311
	40	0.3 ¹⁾	10	RB114	RB309
	40	0.4 ¹⁾	10	RB115	RB310
	40	0.6 ¹⁾	10	RC109	RC309
	40	1.0 ¹⁾	10	RC110	RC310
	40	1.6	5, 5G	RD109	RD309
	30	2.5	5, 5G	RE113	RE313
20	40	1.6	5, 5G	RD110	RD310
	40	2.5	5, 5G	RE114	RE314
	25	4.0	5, 5G	RF116	RF316
25	35	2.5	5, 5G	RE115	RE315
	25	4.0	5, 5G	RF117	RF317
	15	6.3	5, 5G	RG118	RG318

1) metal seated

Kv values determined in accordance with DIN EN 60534. The Kv value specifications refer to the largest actuator for the respective nominal size. The Kv values for other product configurations (e.g. other connections or body materials) may differ.

Product compliance

Food: Regulation (EC) No. 1935/2004*
 Regulation (EC) No. 10/2011*
 FDA*
 * depending on version and/or operating parameters

Pressure Equipment Directive: 2014/68/EU

Machinery Directive: 2006/42/EU

Actuator

EMC Directive: 2014/30/EU

Low Voltage Directive: 2006/95/EC

Interference resistance: DIN EN 61000-6-2
 DIN EN 61326-1 (industrial processes)

Interference emission: DIN EN 61000-6-4 (Sep. 2011)
 Interference emission class: Class A
 Interference emission group: Group 1

Mechanical data

Protection class: IP 65 acc. to EN 60529

Weight: **Actuator**
950 g

Body
DN 15: 2.2 kg
DN 20: 3.0 kg
DN 25: 3.7 kg

Actuating speed: Max. 3 mm/s

Duty cycle and service life

Service life: **Control operation** - Class C according to EN 15714-2 (1,800,000 starts and 1200 starts per hour).
Open/Close duty - At least 500,000 switching cycles at room temperature and permissible duty cycle.

Duty cycle: control module Open/Close control (Code AE)
Duty cycle with full valve lift and playing time 10 minutes.

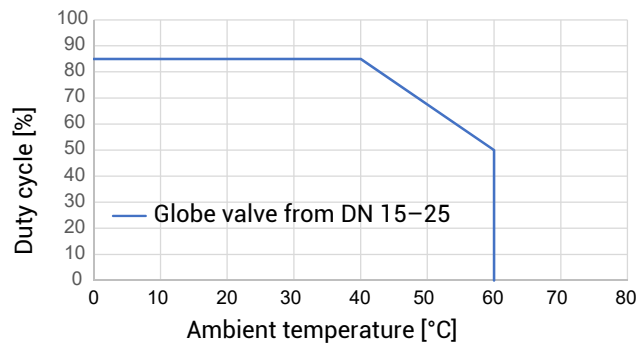

Control module Positioner (code S0), Open/Close duty

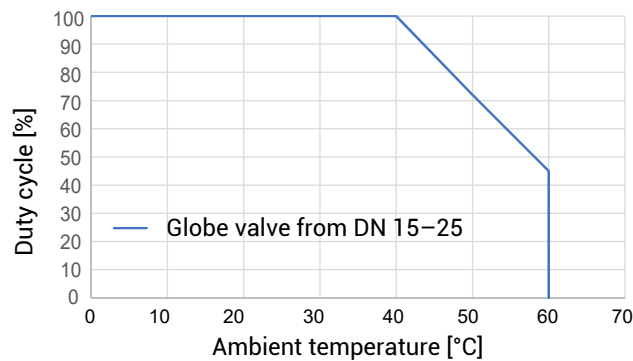

Electrical data

Supply voltage Uv: 24 V DC ± 10%

Rating: 20 W

Analogue input signals – Control module Positioner (code S0)

Set value

Input signals: 0/4 - 20 mA; 0 - 10 V (function selectable via IO-Link)

Input type:	passive
Input resistance:	250 Ω
Accuracy/linearity:	≤ ±0.3% of full flow
Temperature drift:	≤ ±0.1% / 10°K
Resolution:	12 bit
Reverse battery protection:	Yes (up to ± 24 V DC)

Digital input signals

Inputs:	Function selectable via IO-Link (see table Overview of available functions – Input and output signals)
Input voltage:	24 V DC
Logic level "1":	> 15.3 V DC
Logic level "0":	< 5.8 V DC
Input current:	typically < 0.5 mA

Analogue output signals – Control module Positioner (code S0)

Actual value

Output signal:	0/4 - 20 mA; 0 - 10 V (function selectable via IO-Link)
Output type:	active
Accuracy:	≤ ±1% of full flow
Temperature drift:	≤ ±0.1% / 10°K
Load resistor:	≤ 750 kΩ
Resolution:	12 bit
Short-circuit proof:	Yes

Digital output signals

Outputs:	Function selectable via IO-Link (see table Overview of available functions – Input and output signals)
Type of contact:	Push-Pull
Switching voltage:	Power supply U _v
Switching current:	≤ 140 mA
Short-circuit proof:	Yes

Communication

Interface:	IO-Link
Function:	Parameterization/process data
Transmission rate:	38.4 kBaud

Dimensions

Installation and actuator dimensions

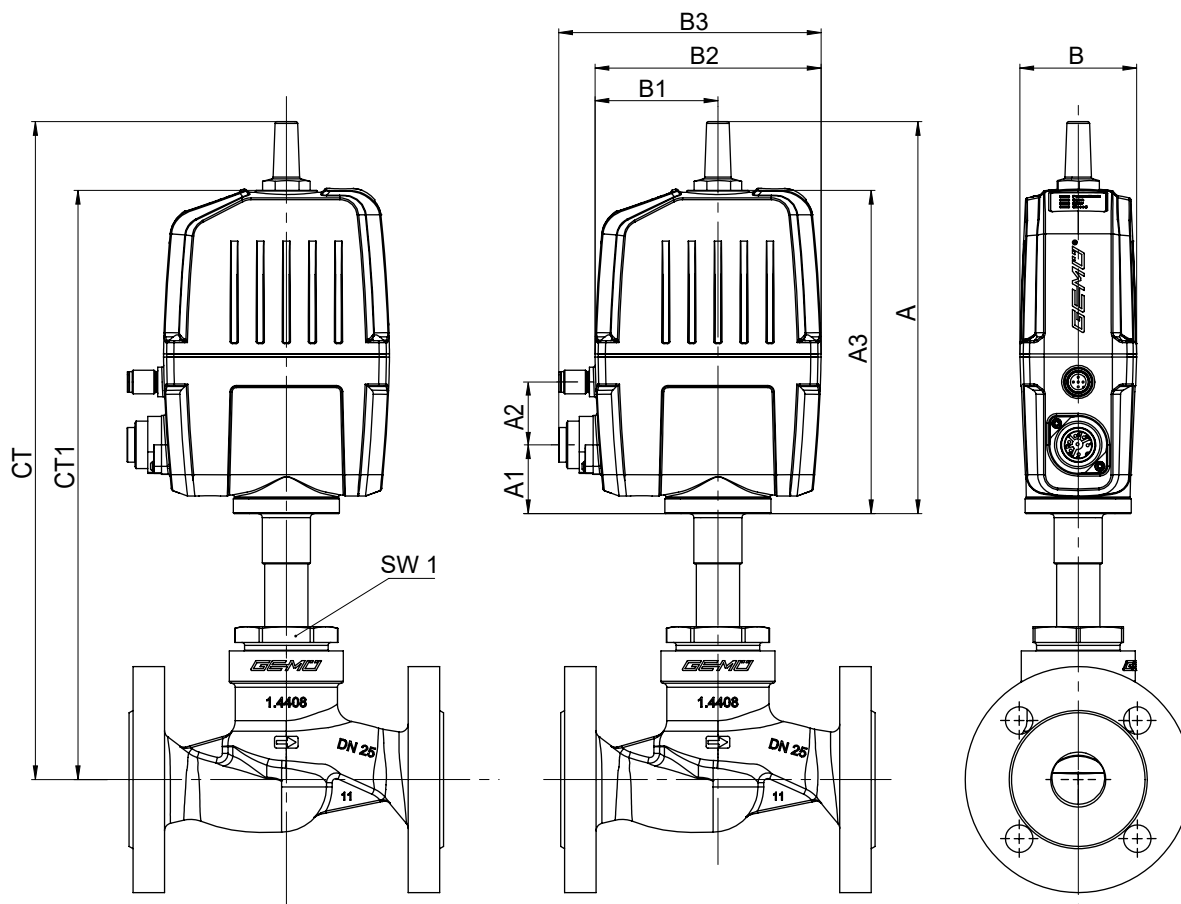

DN	SW 1	A	A1	A2	A3	B	B1	B2	B3	CT	CT1
15	36	197.7	33.2	32	162.7	59.4	62.5	115	133.5	316.8	281.8
20	41	197.7	33.2	32	162.7	59.4	62.5	115	133.5	324.3	289.3
25	46	197.7	33.2	32	162.7	59.4	62.5	115	133.5	334.8	299.8

Dimensions in mm

Dimension A2 only for control module – positioner (code S0)

Body dimensions

Flange connection code 8

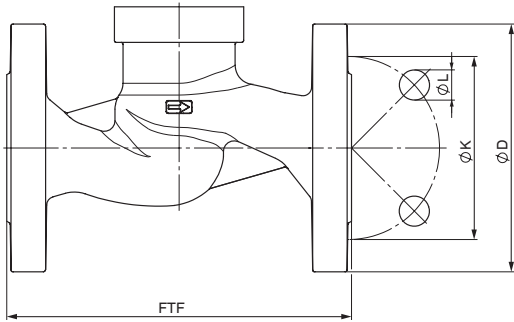

DN	Connection types code 8 ¹⁾				
	Material code 90 ²⁾				
	FTF	ø D	ø L	ø K	n
15	130.0	95.0	14.0	65.0	4
20	150.0	105.0	14.0	75.0	4
25	160.0	115.0	14.0	85.0	4

Dimensions in mm
n = number of bolts

- 1) **Connection type**
Code 8: Flange EN 1092, PN 16, form B, face-to-face dimension FTF EN 558 series 1, ISO 5752, basic series 1
- 2) **Valve body material**
Code 90: EN-GJS-400-18-LT (GGG 40.3)

Flange connection code 10, 11, 48

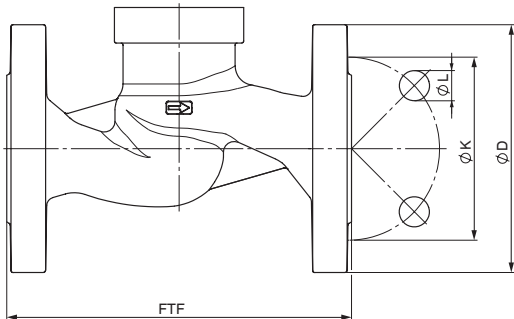

DN	Connection types code ¹⁾														
	10					11					48				
	Material code 37 ²⁾														
	FTF	ø D	ø L	ø k	n	FTF	ø D	ø L	ø K	n	FTF	ø D	ø L	ø K	n
15	130.0	95.0	14.0	65.0	4	130.0	95.0	14.0	65.0	4	108.0	95.0	15.0	70.0	4
20	150.0	105.0	14.0	75.0	4	150.0	105.0	14.0	75.0	4	117.0	100.0	15.0	75.0	4
25	160.0	115.0	14.0	85.0	4	160.0	115.0	14.0	85.0	4	127.0	125.0	19.0	90.0	4

Dimensions in mm
n = number of bolts

- 1) **Connection type**
Code 10: Flange EN 1092, PN 25, form B, face-to-face dimension FTF EN 558 series 1, ISO 5752, basic series 1
Code 11: Flange EN 1092, PN 40, form B, face-to-face dimension FTF EN 558 series 1, ISO 5752, basic series 1
Code 48: Flange JIS 20K, face-to-face dimension FTF EN 558 series 10, ASME/ANSI B16.10 table 1, column 16, DN 50 drilled to JIS 10K
- 2) **Valve body material**
Code 37: 1.4408, investment casting

Flange connection code 39

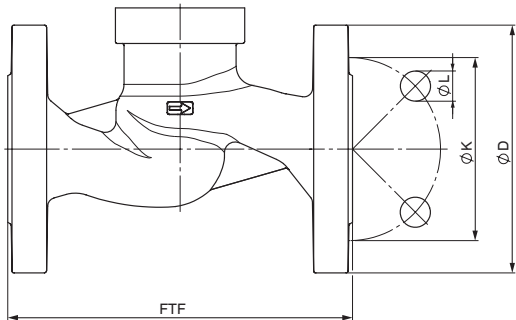

DN	Connection types code 39 ¹⁾				
	Material code 37, 90 ²⁾				
	FTF	φ D	φ L	φ K	n
15	130.0	90.0	15.9	60.3	4
20	150.0	100.0	15.9	69.9	4
25	160.0	110.0	15.9	79.4	4

Dimensions in mm
n = number of bolts

- 1) **Connection type**
Code 39: Flange ANSI Class 125/150 RF, face-to-face dimension FTF EN 558 series 1, ISO 5752, basic series 1
- 2) **Valve body material**
Code 37: 1.4408, investment casting
Code 90: EN-GJS-400-18-LT (GGG 40.3)

Electrical connection

Position of the connectors

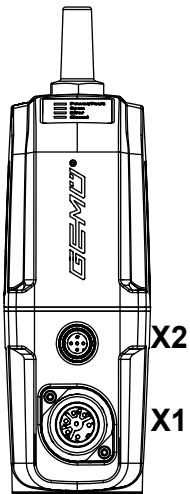

Electrical connection

Connection X1

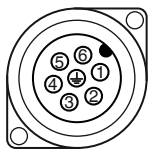

7-pin plug, Binder, type 693

Pin	Signal name
1	Uv, 24 V DC supply voltage
2	GND
3	Digital input 1
4	Digital input 2
5	Digital input / output
6	Digital output, IO-Link
7	n. c.

Connection X2 (only for control module code S0)

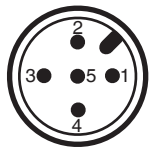

5-pin M12 plug, A-coded

Pin	Signal name
1	I+/U+, set value input
2	I-/U-, set value input
3	I+/U+, actual value output
4	I-/U-, actual value output
5	n. c.

Overview of available functions – Input and output signals

	Function	Default settings		
		Control module AE	Control module A5	Control module A6
Digital input 1	Off Open Close Safe/On Initialization	Open	Open	Open
Digital input 2	Off Open Close Safe/On Initialization	Close	Safe/On	Safe/On
Digital input/output	Open Close Error Error+warning Initialization	Open	Open	Open
Digital output	Open Close Error Error+warning	Close	Close	Close

NOTICE

When configuring the emergency power module (code A5 / A6), the control of the valve changes. Valve is controlled 1-pole via digital input 1. Level logic 1 moves the valve OPEN, level logic 0 moves the valve CLOSE.

	Function	Default settings		
		Control module S0	Control module S5	Control module S6
Digital input 1	Off Open Close Safe/On Initialization	Initialization	Initialization	Initialization
Digital input 2	Off Open Close Safe/On Initialization	Off	Safe/On	Safe/On
Digital input/output	Open Close Error Error+warning Initialization	Error	Error	Error
Digital output	Open Close Error Error+warning	Close	Close	Close
Analogue input	4 – 20 mA 0 – 20 mA 0 – 10 V	4 – 20 mA	4 – 20 mA	4 – 20 mA

	Function	Default settings		
		Control module S0	Control module S5	Control module S6
Analogue output	4 – 20 mA 0 – 20 mA 0 – 10 V	4 – 20 mA	4 – 20 mA	4 – 20 mA

Accessories

GEMÜ 1218



The GEMÜ 1218 is a connector (cable socket / cable plug), 7-pin. Straight and/or 90° angled plug type.

Ordering information

GEMÜ 1218 Binder connector			
Connection X1 – supply voltage, relay outputs			
Binder plug	Mating connector 468/ eSy series	Terminal compartment/ screws, 7-pin	88220649
		Terminal compartment/ screws, 7-pin, 90°	88377714 ¹⁾

1) provided in the scope of delivery

GEMÜ 1219



Cable socket / cable plug M12

The GEMÜ 1219 is a connector (cable socket / cable plug) M12, 5-pin. Straight and/or 90° angled plug type. Defined cable length or with threaded connection without cable. Various materials available for the fixing nut.

Ordering information

Suitable for electrical connection of the connector X2

Description	Length	Order number
5-pin, angle	without cable	88205545
	2 m cable	88205534
	5 m cable	88205540
	10 m cable	88210911
	15 m cable	88244667
5-pin, straight	without cable	88205544
	2 m cable	88205542
	5 m cable	88205543
	10 m cable	88270972
	15 m cable	88346791

GEMÜ

GEMÜ



GEMÜ Gebr. Müller Apparatebau GmbH & Co. KG
Fritz-Müller-Straße 6-8, 74653 Ingelfingen-Criesbach,
Germany
Phone +49 (0)7940 123-0 · info@gemue.de
www.gemu-group.com