

- > **Port size: G1 ... G3**
- > **Provides an excellent control of upstream pressure**
- > **Internal and external dome loading**
Note: no pilot regulator needed for internal dome loading for gas service
- > **Provides repeatable and accurate over pressure protection where relief valve hysteresis and endurance are insufficient**



Technical features

The M30 series is a balanced dome loaded pressure maintaining valve, used for quick and accurate control of inlet pressures. Ideal for high flow and low to medium pressure applications. It is a stable valve for maintaining a set pressure of upstream media, its heavy duty construction allows it to be installed in the most arduous of environments.

Applications:

- Compressors
- Dryer systems
- Filter systems
- Brewery plants
- Gas & liquid sampling
- Pump pressure control
- Research laboratories

Medium:

Liquid and gases

Maximum inlet pressure:

M31 & M32: 70 barg (1015psig)

M33: 55 barg (798psig)

Control pressure range:

M31 & M32:

0,5 ... 70 barg (7.3 ... 1015 psig)

M33:

0,5 ... 42 barg (7.3 ... 609 psig)

Flow:

See table below

Dome loading:

Internal or external via G1/4 connection.

Domes should be loaded with air or inert gas.

Leakage:

Bubble tight (standard, typically 10^{-6} atm. $\text{cm}^3/\text{sec}^{-1}$)

Helium leak tested to 10^{-8} atm. $\text{cm}^3/\text{sec}^{-1}$ (on request)

Ambient/Media temperature:

NBR:

-10 ... +100°C (+14 ... 212°F)

FPM:

-20 ... +150°C (-4 ... 302°F)

EPDM:

-30 ... +115°C (-22 ... 239°F)

Nodular iron body

-20 ... +150°C (-4 ... 302°F)

Stainless Steel

-40 ... +150°C (-40 ... 302°F)

Materials:

Body: cast stainless steel
 BS EN10213 PT.4 1.4408 or cast nodular iron
 BS EN1563 EN-GJS-400-18LT
 Dome: cast stainless steel
 BS EN10213 PT.4 1.4408 or cast nodular iron
 BS EN1563 EN-GJS-400-18LT
 Seat: stainless steel BN ES 10088 1.4401
 Trim: Elastomer
 Elastomers: NBR, FPM, EPDM

Options:

Welded flanges upon request (Stainless Steel regulators only)

Technical data

Symbol	Port size	Valve seat size		Seat flow area		Port flow area		Flow coefficient		Model
		(mm)	(inch)	(mm ²)	(inch ²)	(mm ²)	(inch ²)	(Kv)	(Cv)	
	1"	12,7	0.5	97	0.15	387	0.60	2,9	3.4	M31
	2"	25,4	1	323	0.50	1503	2.33	9,7	7.9	M32
	3"	38,1	1.5	968	1.50	2858	4.43	29	34	M33

Option selector

Port size	Substitute	M3★★★★		Elastomer	Substitute
G1	1			NBR	N
G2	2			FPM	V
G3	3			EPDM	E
Material	Substitute				
Cast nodular iron	P8				
Stainless steel	9H				

Option selector spare kits

M3★S★

Port size	Substitute
G1	1
G2	2
G3	3

Elastomer	Substitute
NBR	N
FPM	V
EPDM	E

Spares BOM

Description	Material	QTY
Bonded seal	Steel/ Rubber	1
Circlip	BS 5216-HD 3	2
Needle valve	BS 3S 145 (normalised)	2
'O'-Ring	Rubber	2
Standard diaphragm	Rubber	1
'O'-Ring	Rubber	1
Valve pad	Rubber	1
'O'-Ring	Rubber	1
'O'-Ring	Rubber	1
'O'-Ring	Rubber	1

Dimensions

Dimensions in mm
Projection/First angle

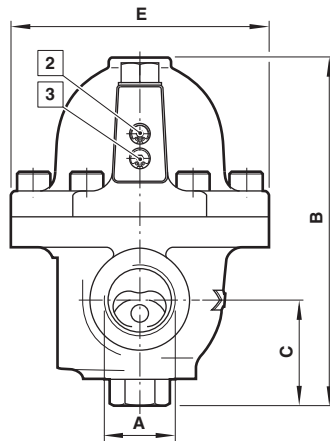
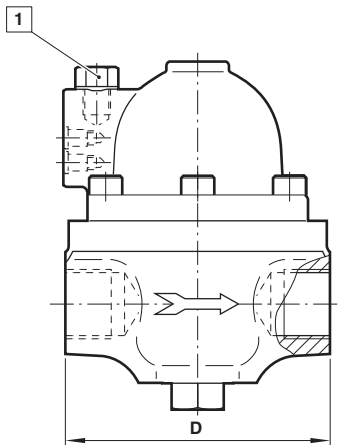

- 1 G1/4 dome vent and external load connection (plugged)
- 2 Load regulation screw for external or internal pressure
- 3 Load regulation screw for internal pressure only

A	B	C	D	E	Weight (kg)	Model
G 1	167	51	127	124	5,5	M31
G 2	266	78	227	197	18,5	M32
G 3	315	97	254	229	32	M33

Warning

Do not use these products where pressures and temperatures can exceed those listed under »**Technical features**«.

Before using these products with fluids other than those specified within published specifications, consult IMI Precision Engineering, Thompson Valves Ltd.

Through misuse, age, or malfunction, components used in fluid power systems can fail in various modes.

The system designer is warned to consider the failure modes of all component parts used in fluid power systems and to provide adequate

safeguards to prevent personal injury or damage to equipment in the event of such failure.

System designers must provide a warning to end users in the system instructional manual if protection against a failure mode cannot be adequately provided.

System designers and end users are cautioned to review specific warnings found in instruction sheets packed and shipped with these products.