

- > **Port size: G1 ... G3**
- > **Internal and external dome loading**
Note: no pilot regulator needed for internal dome loading for gas service
- > **Balanced design ensures a stable delivery pressure, even with a varying inlet pressure**
- > **Design option offers optimised performance at very low delivery pressures (< 5 barg)**



Technical features

K30 Series Dome Loaded Pressure Regulators offer excellent pressure control at low to medium delivery pressures. Below 5 barg, the build standard is adjusted to increase sensitivity offering improved pressure control and flow performance. Its heavy duty construction makes the K30 Series ideal for arduous conditions and harsh environments.

Applications:

- Medium to Low Pressure Gas Supply Applications
- Liquid Pressure Control Applications
- Industries such as Oil & Gas, Marine, CNG, Industrial Gas, Brewing and Mining

Medium:

Liquid and gases

Maximum inlet pressure:

K31 & K32: 70 barg (1015 psig)
 K33: 55 barg (798 psig)

Outlet pressure range:

K31 & K32:
 0,5 ... 70 barg (7.3 ... 1015 psig)
 K33: 0,5 ... 42 barg (7.3 ... 609 psig)

Low pressure version:

Inlet pressure: 25 barg (363 psig)
 Outlet pressure:
 0,1 ... 5 barg (1.4 ... 73 psig)

Typical flow – valve size:

See table below

Dome loading:

Internal or external via G 1/4 connection.

Domes should be loaded with air or inert gas.

Leakage:

Bubble tight (standard, typically 10^{-6} atm.cm³/sec⁻¹)
 Helium leak tested to 10^{-8} atm.cm³/sec⁻¹ (on request)

Ambient/Media temperature:

NBR:
 -10 ... +100°C (+14 ... +212°F)
 FPM:
 -20 ... +150°C (-4 ... +302°F)
 EPDM:
 -30 ... +115°C (-22 ... +239°F)
 Nodular iron
 -20 ... +150°C (-4 ... +302°F)
 Stainless Steel
 -40 ... +150°C (-40 ... +302°F)

Materials:

Body: cast stainless steel
 BS EN 10213 PT.4 1.4408 or cast nodular iron
 BS EN1563 EN-GJS-400-18-LT
 Dome: cast stainless steel
 BS EN 10213 PT.4 1.4408 or cast nodular iron
 BS EN1563 EN-GJS-400-18-LT
 Seat: stainless steel BS EN 10088 1.4401
 Trim: Elastomer
 Elastomers: NBR, FPM, EPDM

Options:

Welded flanges upon request (Stainless Steel regulators only)

Technical data

Symbol	Port size	Valve seat size (mm)	Valve seat size (inch)	Seat flow area (mm ²)	Seat flow area (inch ²)	Port flow area (mm ²)	Port flow area (inch ²)	Flow coefficient (Kv)	Flow coefficient (Cv)	Model
	G1	12,7	0.5	97	0.15	387	0.60	2,9	3,4	K31
	G2	25,4	1	323	0.50	1503	2.33	9,7	7.9	K32
	G3	38,1	1 1/2	968	1.50	2858	4.43	29	34	K33

Option selector

Port size	Substitute	K3★★★★★		Elastomer	Substitute
G1	1			NBR	N
G2	2			FPM	V
G3	3			EPDM	E
Material	Substitute			Outlet pressure	Substitute
Cast nodular iron	P8			Standard	S
Stainless steel	9H			Low pressure	L

Option selector spare kits

K3★S★★★

Port size	Substitute
G1	1
G2	2
G3	3

Elastomer	Substitute
NBR	N
FPM	V
EPDM	E
Outlet pressure	Substitute
Standard	S
Low pressure	L

Spares BOM

Description	Material	QTY	Required	
			Standard pressure	Low pressure
Bonded seal	Steel	1	X	X
Circlip	BS 5216-HD 3	2	X	X
Needle valve	BS 3S 145 (normalised)	2	X	X
'O'-Ring	Rubber	2	X	X
Standard diaphragm	Rubber	1	X	—
'O'-Ring	Rubber	1	X	X
Spring	Various	1	X	X
'O'-Ring	Rubber	1	X	X
Seat	BS EN 10088 1.4401	1	X	X
Valve assy (PAD only)	Various	1	X	X
'O'-Ring	Rubber	1	X	X
'O'-Ring	Rubber	1	X	X
Gasket	Rubber	1	—	X
Low pressure diaphragm	Rubber	1	—	X

Dimensions

Dimensions in mm
 Projection/First angle

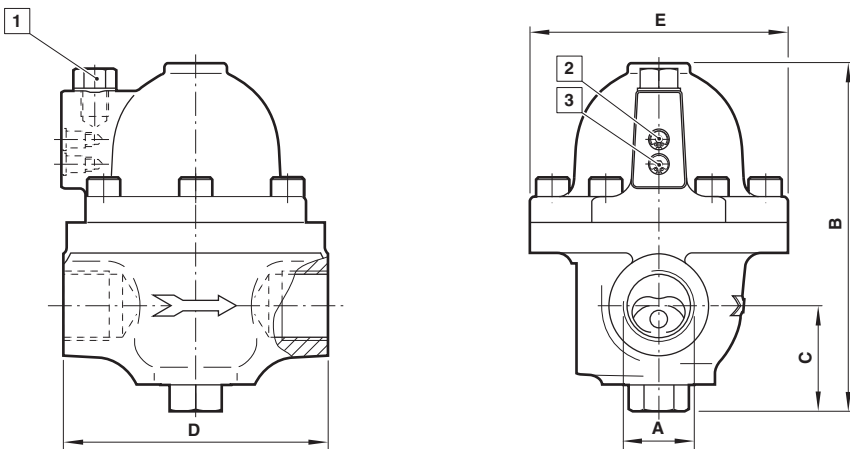

- 1 G1/4 dome vent and external load connection (plugged)
- 2 Load regulation screw for external or internal pressure
- 3 Load regulation screw for internal pressure only

A	B	C	D	E	Weight (kg)	Model
G 1	167	51	127	124	5,5	K31
G 2	266	78	227	197	18,5	K32
G 3	315	97	254	229	32	K33

Warning

Do not use these products where pressures and temperatures can exceed those listed under »**Technical features**«.

Before using these products with fluids other than those specified within published specifications, consult IMI Precision Engineering, Thompson Valves Ltd.

Through misuse, age, or malfunction, components used in fluid power systems can fail in various modes.

The system designer is warned to consider the failure modes of all component parts used in fluid power systems and to provide adequate

safeguards to prevent personal injury or damage to equipment in the event of such failure.

System designers must provide a warning to end users in the system instructional manual if protection against a failure mode cannot be adequately provided.

System designers and end users are cautioned to review specific warnings found in instruction sheets packed and shipped with these products.