

Hydraulic Overload Protection Unit DN 16-63
Overload protection for mechanical presses prevents machine components and tools from damage and excessive load

- Directly acting overload protection**
- Fast reponse times < 10 ms**
- Low pressure peaks**
- Excellent repeatability**
- Infinitely variable adjustment of press force, set either by manual or electronic control**
- Suitable for double crank presses with unbalanced load**
- Suitable for automated machines**
- Quick and easy resetting after overload tripping**
- Suitable as measuring device for determination of press force**



Technical data

Operating fluid:
Hydraulic oil

Cut-off pressure
 P_A max [bar]:
420

Hydraulic fluid temp.
 ϑ_m max. [°C]:
70

Ambient temp. range
 ϑ_m max. [°C]:
-20 to +50

Viscosity range
 ν [mm²]:
12 to 500

Mounting position:
any

Seal material:
Perbunan, Viton on request

Ordering example

see page 6

Hydraulic Overload Protection Unit DN 16-63

Design

Pilot operated hydraulic pressure control valve, cartridge type.

For single crank presses

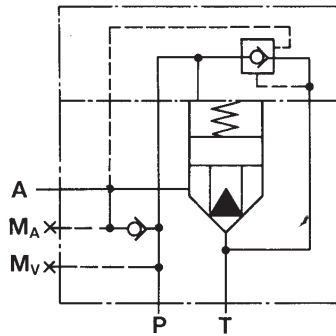

For double crank presses

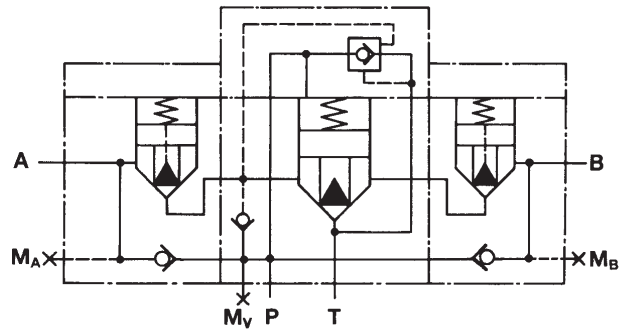

Mode of operation (general)

An oil-filled cylinder which serves as a cushion is situated in the flux path between connecting rod and slide. The cylinder is preloaded with hydraulic pressure p_v .

At each operating stroke the hydraulic pressure increases but remains below the set cut-off pressure p_A .

In an overload situation the cut-off pressure is reached causing the valve to open. The hydraulic pressure breaks down immediately and releases the slide from the mechanical load.

The delay in response depends on the operating conditions and on the quality of the overload protection system. The requirement to achieve the fastest possible response is fulfilled by the system described in this brochure.

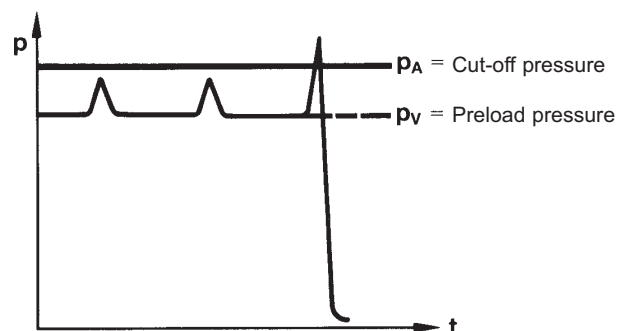
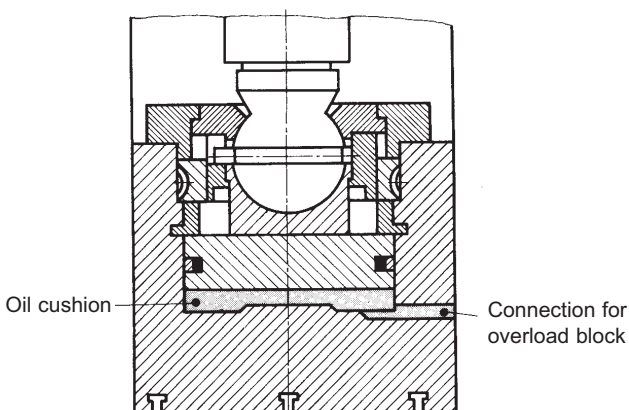

Hydraulic Overload Protection Unit DN 16-63

Function

- For single crank presses (as illustrated)
- For multiple crank presses with balanced load on connecting rods
- Setting of the cut-off pressure either manually (as illustrated) or electrically from a remote source
- For double crank presses with unbalanced load on connecting rods
- Adjustment of cut-off pressure either manually or electrically from a remote source (as illustrated)

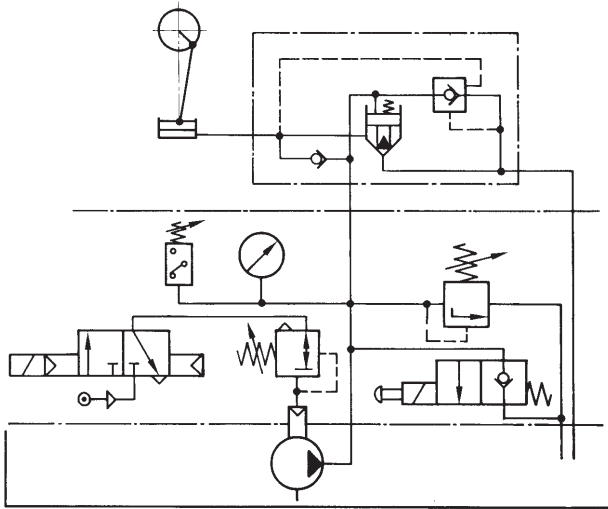

The preload pressure in the oil cushion cylinder is produced by means of a pneumatically driven hydraulic pump. The actual value of the pressure is a function of the setting of the air-pressure regulating valve and the translation ratio of the pump.

The difference between preload and cut-off pressures is governed by the piston area ratio in the pilot valve of the overload block. In the pilot valve the increase in pressure corresponding to an overload situation acts against the preload pressure and, at a level determined by the piston area ratio, causes the pilot valve to open. This in turn releases pressure at the control side of the main valve which then also opens so that the cushion cylinder pressure falls to zero.

The actual level of the cut-off pressure can be set as required by adjusting the air pressure at the pressure control valve. As the preload pressure acts on the check valve, it is necessary to release the pressure prior to adjusting the cut-off pressure to a lower value. This is accomplished either electrically or manually by means of a 2-way valve.

The pressure switch which indicates that the system is ready for operation is set at 50 bar. In an overload situation the electrical contact is used to switch off the press and to shut off the air pressure by means of a 3/2 directional valve.

The pressure relief valve in the hydraulic circuit is set to correspond to the maximum press force and serves to protect the machine in the event of an incorrect adjustment of the overload protection system.

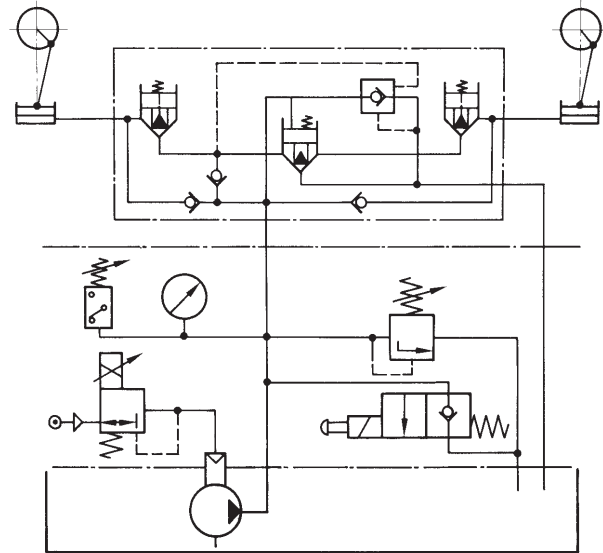

For this arrangement, the cut-off pressure is set by means of a proportional pressure control valve. This valve is closed when switched off so that the 3/2 directional valve is not required.

In an unbalanced overload situation, non-return valves fitted into the valve block prevent interaction between the pressure cushion cylinders, thus avoiding canting of the press slide.

The various circuits illustrated can be combined to meet applications as required.



Power packs are standardly available with 12.5, 25, 40 and 63 liter tanks.

Further arrangements are available on request.

Installation

Flanged type

- For single crank presses

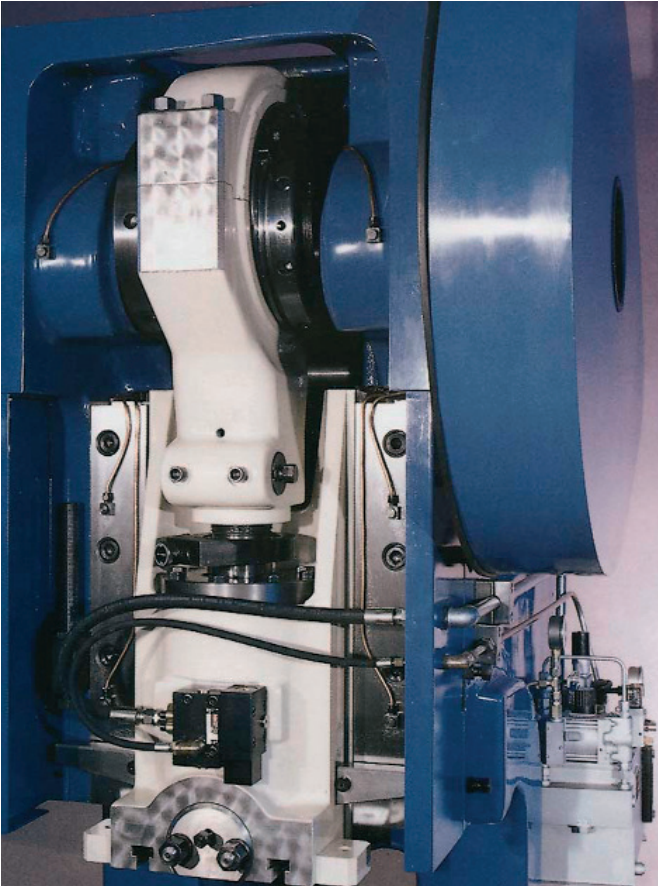

The overload valve block is bolted directly onto the connection of the cylinder volume.

This installation offers minimum resistance to the fluid flow as additional pipe connections between oil cushion and valve are not required.

The arrangement is particularly effective with respect to achieving fast response during overload. Fitting of the block is quickly and easily carried out.

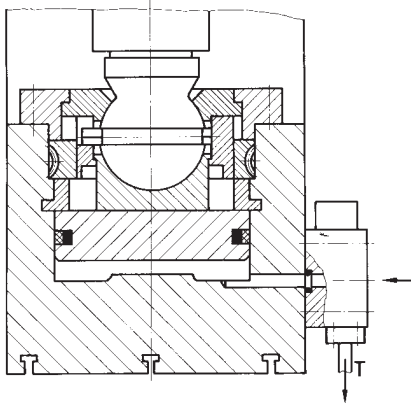

Inline type

- For double or multiple crank presses



For double crank press applications the overload prevention unit has to be fitted inline.

In order to achieve faster response, the piping should be arranged to offer minimum resistance to the fluid flow.

For single crank presses where it is not possible to flange the valve (e.g. lack of space), it may be necessary to install the inline type. In this case the port which is no longer used is sealed by a plate. As this requirement occurs only occasionally in practice, it is not considered further in this brochure.

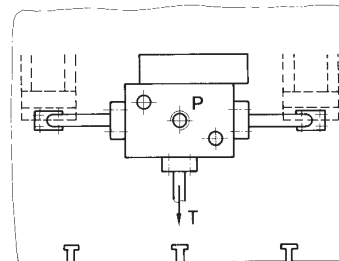

Selection and calculation

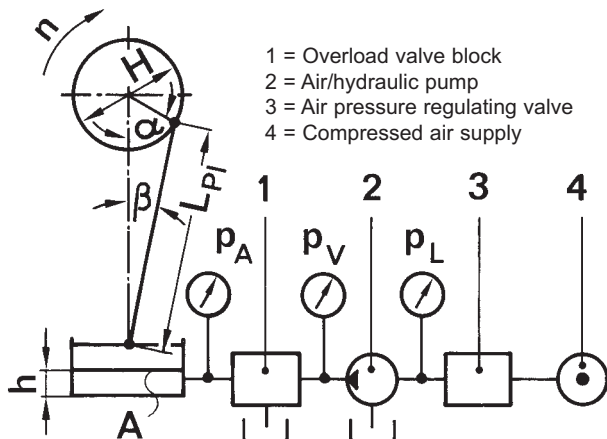

- 1 = Overload valve block
- 2 = Air/hydraulic pump
- 3 = Air pressure regulating valve
- 4 = Compressed air supply

Cut-off pressure

The press is protected against overload at the cut-off pressure p_A . The value of the cut-off pressure may be obtained theoretically using the following calculation, but in any event may not exceed the allowable max. pressure of 420 bar.

$$P_A = \frac{10^4 \cdot F}{A} \text{ [bar]}$$

F [kN] = Nominal press force

A [mm²] = Total pressure area of pressure cushion(s)

In the final calculation the deformation of the pressure cushion must be allowed for.

Nominal size

The calculation size DN is obtained from the following formula. The next larger size from the sales program will then be the correct one for the application in question.

$$DN = \sqrt{\frac{n \cdot H \cdot A \cdot \sin(\alpha + \beta)}{7,5 \cdot 10^5 \cdot \cos\beta}} \text{ [mm]}$$

n [min⁻¹] = Speed of crankshaft

H [mm] = Crank diameter (stroke)

A [mm²] = Total pressure area of pressure cushion(s)

$$\cos \alpha [-] = \frac{H - 2h}{H}$$

h [mm] = Overload travel. This is the distance from the lowest point of slide movement to the point where the overload protection system must react in the least favourable case. This distance is determined by the machine manufacturer.

$$\sin \beta [-] = \sin \alpha \cdot \frac{H}{2 \cdot L_{P1}}$$

L_{P1} [mm] = Length of connecting rod

Preset values

Setting of the overload protection unit depends upon chosen values for:

- Cut-off pressure
- Area ratio of the valve piston
- Translation ratio of the pump
- Air pressure

If, for example, a cut-off pressure of 390 bar is required, then using a standard first stage valve piston of area ratio 1:1.3 and a standard pump translation ratio of 1:60, the compressed air pressure is calculated as follows:

$$P_I = \frac{390}{1.3 \cdot 60} = 5 \text{ [bar]}$$

This results in a hydraulic preload pressure of

$$P_V = \frac{390}{1.3} \text{ or } 5 \cdot 60 = 300 \text{ bar}$$

When establishing system parameters it is necessary to observe that the compressed air pressure does not fall below the minimum adjustable value of 1.5 bar, and also that the maximum allowable supply pressure is not exceeded.

Types

After the nominal bore size has been established, the type of the overload protection unit is selected. The selection depends on the press type as well as the connecting rod loading characteristics.

Hydraulic Overload Protection Unit DN 16-63

Type codes, type survey, technical information

Type codes for overload block

D	AV	S	25	F	99	011	3	O	O
1	2	3	4	5	6	7	8	9	10

- | | | | | | | | |
|---|----------------------------|-----------|--|----|----------------------|------------|-----------------------------|
| 1 | Equipment group: | D | – Pressure valve | 6 | Pressure stage: | 99 | – > 315 bar |
| 2 | Operating characteristics: | AV | – Pressure cut-off with selected piston area ratio | 7 | Code No.: | 010 | – Without non-return valves |
| | | | | | | 011 | – With non-return valves |
| 3 | Design: | S | – Poppet valve, pilot controlled | 8 | Engineering version: | 3 | – DIN-Cartridge |
| 4 | Nominal size: | 16 | | 9 | Cut-off ratio: | A | – Standard type |
| | | 25 | | | | O | – Special design |
| | | 40 | | 10 | Seal material: | O | – Perbunan |
| | | 63 | | | | V | – Viton |
| 5 | Connection: | A | – Flanged | | | | |
| | | F | – Inline | | | | |
| | | K | – remote control pilot operated | | | | |

Type survey

Overload valve block					Flanges, SAE 6000 to be welded *)		
DN	Type	Typ code	Weight	Order No.	Port A	Port B	Port T
16	Flanged	DAVS16A990103AO 1:1,15	6.7 kg	6015856	–	–	G1/2
16	Flanged	DAVS16A990103AO 1:1,3	6.7 kg	6015853	–	–	G1/2
16	Flanged	DAVS16A990103AO 1:1,6	6.7 kg	6015855	–	–	G1/2
16	Flanged	DAVS16A990103AO 1:1,9	6.7 kg	6015854	–	–	G1/2
16	Inline	DAVS16F990103AO 1:1,15	7.2 kg	6015887	G1/2	G1/2	G1/2
16	Inline	DAVS16F990103AO 1:1,3	7.2 kg	6015884	G1/2	G1/2	G1/2
16	Inline	DAVS16F990103AO 1:1,6	7.2 kg	6015886	G1/2	G1/2	G1/2
16	Inline	DAVS16F990103AO 1:1,9	7.2 kg	6015885	G1/2	G1/2	G1/2
25	Flanged	DAVS25A990103AO 1:1,15	8.9 kg	6015925	–	–	G1
25	Flanged	DAVS25A990103AO 1:1,3	8.9 kg	6015922	–	–	G1
25	Flanged	DAVS25A990103AO 1:1,6	8.9 kg	6015924	–	–	G1
25	Flanged	DAVS25A990103AO 1:1,9	8.9 kg	6015923	–	–	G1
25	Inline	DAVS25F990103AO 1:1,15	15.1 kg	6015844	G1	G1	G1
25	Inline	DAVS25F990103AO 1:1,3	15.1 kg	6015841	G1	G1	G1
25	Inline	DAVS25F990103AO 1:1,6	15.1 kg	6015843	G1	G1	G1
25	Inline	DAVS25F990103AO 1:1,9	15.1 kg	6015842	G1	G1	G1
25	Inline, with non-return valve	DAVS25F990113AO 1:1,15	15.1 kg	6015907	G3/4	G3/4	G1
25	Inline, with non-return valve	DAVS25F990113AO 1:1,3	15.1 kg	6015903	G3/4	G3/4	G1
25	Inline, with non-return valve	DAVS25F990113AO 1:1,6	15.1 kg	6015906	G3/4	G3/4	G1
25	Inline, with non-return valve	DAVS25F990113AO 1:1,9	15.1 kg	6015905	G3/4	G3/4	G1
25	Flanged remote pilot operated	DAVS25KA99010200	9 kg	8130354	–	–	G1

*) Flanges to be ordered separately.

Geräteübersicht

Overload valve block					Flanges, SAE 6000 to be welded *)		
DN	Type	Typ code	Weight	Order No.	Port A	Port B	Port T
40	Flanged	DAVS40A990103AO 1:1.15	22.5 kg	6015932	–	–	G1 1/2
40	Flanged	DAVS40A990103AO 1:1.3	22.5 kg	6015929	–	–	G1 1/2
40	Flanged	DAVS40A990103AO 1:1.6	22.5 kg	6015931	–	–	G1 1/2
40	Flanged	DAVS40A990103AO 1:1.9	22.5 kg	6015930	–	–	G1 1/2
40	Inline	DAVS40F990103AO 1:1.15	27.5 kg	6015938	G1 1/2	G1 1/2	G1 1/2
40	Inline	DAVS40F990103AO 1:1.3	27.5 kg	6015935	G1 1/2	G1 1/2	G1 1/2
40	Inline	DAVS40F990103AO 1:1.6	27.5 kg	6015937	G1 1/2	G1 1/2	G1 1/2
40	Inline	DAVS40F990103AO 1:1.9	27.5 kg	6015938	G1 1/2	G1 1/2	G1 1/2
40	Inline, with non-return valve	DAVS40F990113AO 1:1.15	27.5 kg	6015832	G1 1/4	G1 1/4	G1 1/2
40	Inline, with non-return valve	DAVS40F990113AO 1:1.3	27.5 kg	6015829	G1 1/4	G1 1/4	G1 1/2
40	Inline, with non-return valve	DAVS40F990113AO 1:1.6	27.5 kg	6015831	G1 1/4	G1 1/4	G1 1/2
40	Inline, with non-return valve	DAVS40F990113AO 1:1.9	27.5 kg	6015830	G1 1/4	G1 1/4	G1 1/2
40	Flange remote pilot operated	DAVS40KA99010200	30.0 kg	6015560	–	–	G1 1/2
63	Flanged	DAVS63A990103AO 1:1.3	75 kg	8130875	–	–	G2 1/2
63	Inline	DAVS63F990103AO 1:1.3	70 kg	8130624	–	–	G2 1/2
63	Flanged remote pilot operated	DAVS63KA99010200	69 kg	6103420	–	–	G2 1/2

*) Flanges to be ordered separately.

Spare parts for flanges

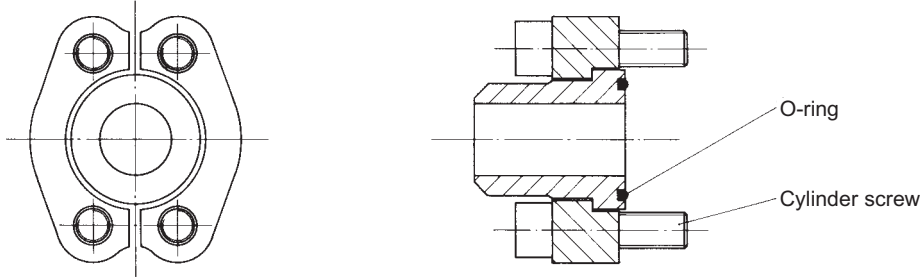

Part	Part name	SAE 6000-G1/2	SAE 6000-G3/4	SAE 6000-G1	SAE 6000-G1 1/4	SAE 6000-G1 1/2	Order No. NBR 70	Order No. NBR 90
1	O-ring (18.64 x 3.53)	1	-	-	-	-	0701338	0701544
1	O-ring (25.0 x 3.53)	-	1	-	-	-	0701342	0701548
1	O-ring (32.93 x 3.53)	-	-	1	-	-	0701347	0701553
1	O-ring (37.7 x 3.53)	-	-	-	1	-	0701350	0701556
1	O-ring (47.23 x 3.53)	-	-	-	-	1	0701353	0701559
Mounting screws								
2	Cylinder screw (M 8 x 30 DIN 912-10.9)	4	-	-	-	-	0700437	
2	Cylinder screw (M 10 x 40 DIN 912-10.9)	-	4	-	-	-	0701366	
2	Cylinder screw (M 12 x 45 DIN 912-10.9)	-	-	4	-	-	0700472	
2	Cylinder screw (M 14 x 50 DIN 912-10.9)	-	-	-	4	-	0663356	
2	Cylinder screw (M 16 x 55 DIN 912-10.9)	-	-	-	-	4	0700492	

Flanges	kg	Order No.	Flanges	kg	Order No.
SAE 6000-G1/2	0.3	0769876	SAE 6000-G1 1/4	1.4	0764879
SAE 6000-G3/4	0.6	0764877	SAE 6000-G1 1/2	2.4	0764880
SAE 6000-G1	0.9	0764878	SAE 3000-G2 1/2	1.7	1450274

Hydraulic Overload Protection Unit DN 16-63

Dimensions

Flanged type D AV S..A 99 010 2 A O

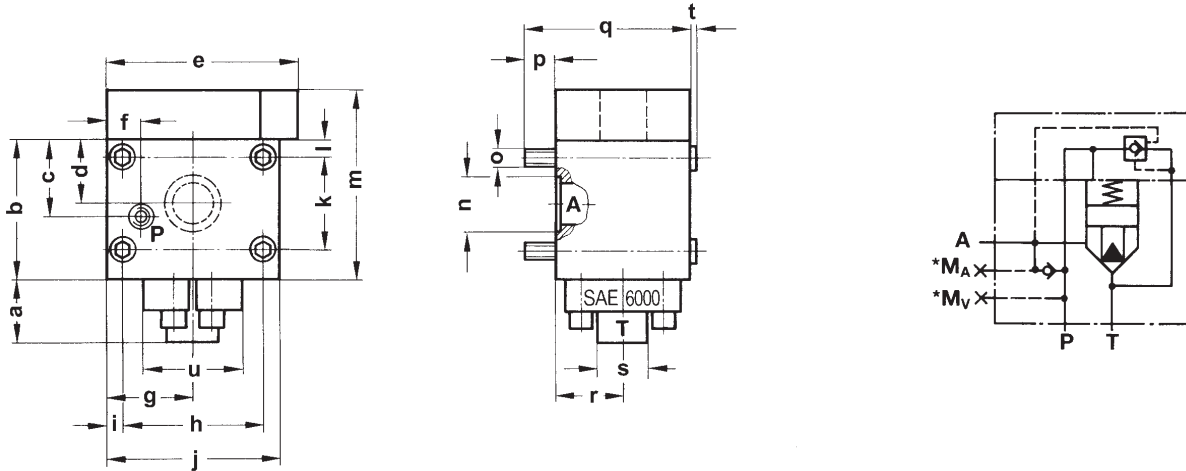

DN	a	b	c	d	e	f	g	h	i	j	k	l	m	n	o	p
16	40	75	32	31	124.5	20	47.5	75	10	110	40	11	123	∅26.5	M 10	15
25	50	95	45	42.5	140.5	22	57.5	90	12.5	115	60	12.5	143	∅34.2	M 12	20
40	60	135	75	62	184.5	32.5	82.5	135	15	165	90	17	183	∅53	M 16	30
63	-	200	90	95	267	115	115	190	20	230	105	45	300	∅78.6	M 20	27
DN	q	r	s	t	u	A		T	P	M _A	M _V					
16	85	33	22	5	48	∅16		G1/2	G3/8	G1/4	G1/4					
25	110	43	38	2	70	∅25		G1	G1/2	G1/4	G1/4					
40	160	65	50	6	96	∅40		G1 1/2	G1/2	G1/4	G1/4					
63	237	45	-	6	-	∅63		G2 1/2								

Inline type D AV S..F 99 010 2 A O

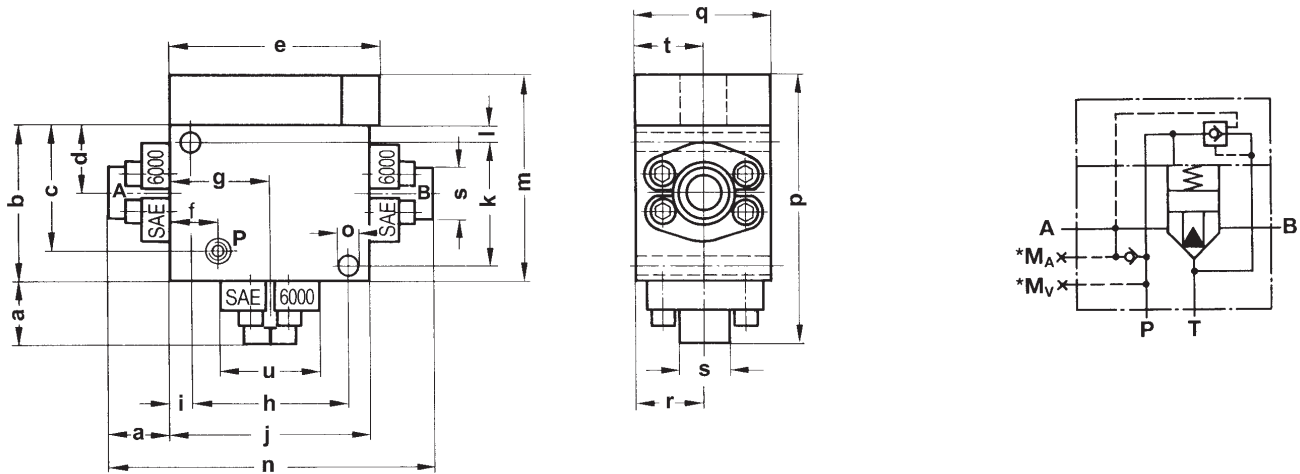

DN	a	b	c	d	e	f	g	h	i	j	k	l	m	n	o	p
16	40	90	67	34	132	30	55	90	10	110	70	10	138	190	9	178
25	50	125	85	44	153	37	70	116	12	140	101	12	173	240	13	223
40	60	150	120	64	197	45	95	150	20	190	120	15	198	310	18	258
63	-	200	90	95	300	150	150	270	15	300	170	15	300	-	18	-
DN	q	r	s	t	u	A		B	T	P	M _A	M _V				
16	80	40	22	40	48	G1/2		G1/2	G1/2	G3/8	G1/4	G1/4				
25	110	55	38	50	70	G1		G1	G1	G1/2	G1/4	G1/4				
40	130	65	50	65	96	G1 1/2		G1 1/2	G1 1/2	G1/2	G1/4	G1/4				
63	330	215	-	60	-	2 x G2		G2 1/2								

Hydraulic Overload Protection Unit DN 16-63

Inline type with non-return valves D AV S..F 99 011 2 A O

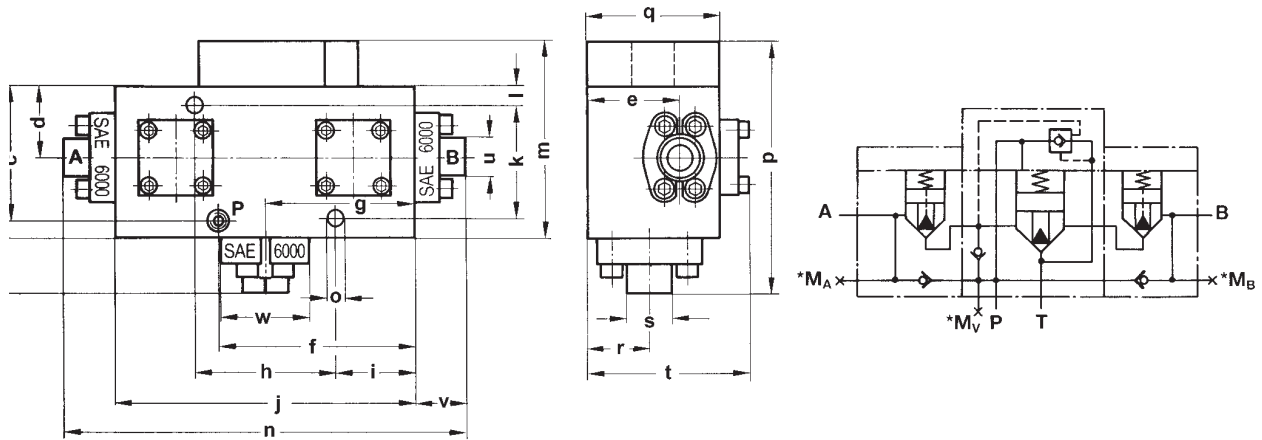

DN	a	b	c	d	e	f	g	h	i	j	k	l	m	n	o	p												
25	50	130	112	45	77	148	115	116	50	230	101	14	178	320	13	228												
40	60	160	143	75	98	210	160	150	85	320	120	20	208	430	18	268												
DN	q	r	s	t	u	v	w	A			B			T			P			MA			MB			MV		
25	1109	50	38	133	31,8	45	70	G3/4			G3/4			G1			G1/2			G1/4			G1/4			G1/4		
40	140	65	50	172	42	55	96	G1 1/4			G1 1/4			G1 1/2			G1/2			G1/4			G1/4			G1/4		

Flanged type, remote pilot operated D AV S..KA 99 010 2 O O

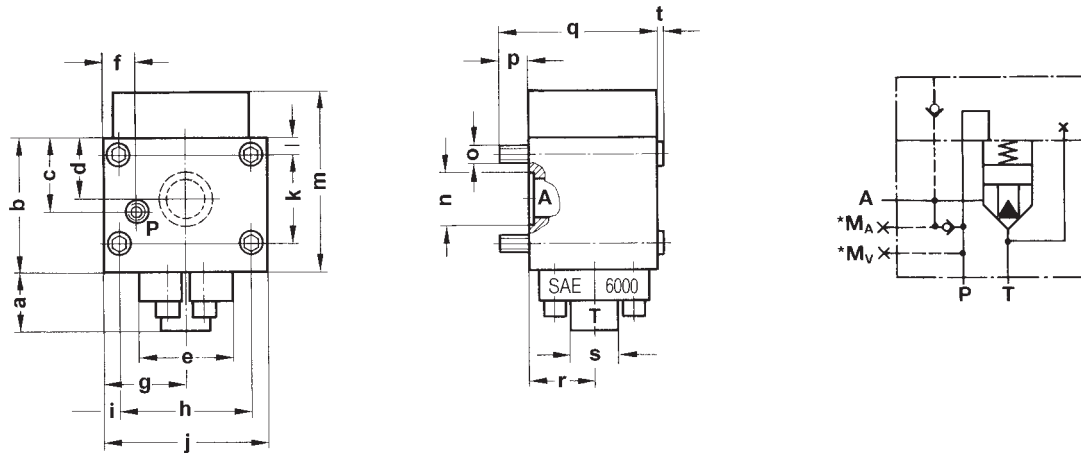

DN	a	b	c	d	e	f	g	h	i	j	k	l	m	n	o	p									
16																									
25																									
40	60	135	75	62	96	32,5	82,5	135	15	165	90	17	183	∅53	M 16	30									
63	-	200	25	95	-	115	95	190	20	230	105	50	270	∅78,6	M 20	27									
DN	q	r	s	t	A			T			P			MA			MV								
16																									
25																									
40	160	65	50	6							∅40			G1 1/2			G3/8			G1/4			G1/4		
63	197	95	-	0																					

* The connections for pressure gauges MA, MB and MV are not shown in the installation drawings.

Questionnaire for hydraulic overload protection unit

Supplier



Systemtechnik GmbH

Untere Talstraße 65
71263 Weil der Stadt
Tel.: +49 (0) 70 33/30 18-0
Fax: +49 (0) 70 33/30 18-10
info@herion-systemtechnik.de

Customer

Address _____

 Department _____
 Contact _____
 Telephone _____
 Date _____

Press description

Press type _____

 Model _____

Press specification data

Max. press force	F = _____ kN
Max. stroke	H = _____ mm
Max. speed	n = _____ min ⁻¹
Travel during overload or Angle before BDC where system is respond	h = _____ mm = _____ degree
Length of connecting rod	L _{PI} = _____ mm
Total area of pressure cushion or Piston diameter	A = _____ mm ² D = _____ mm
Number of connecting rods	z = _____ -
Load on connecting rod	Balanced <input type="checkbox"/> Unbalanced <input type="checkbox"/>

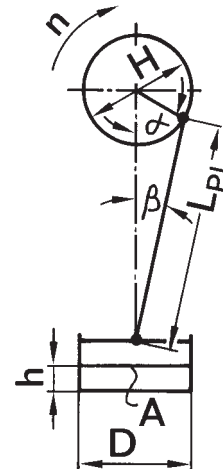

Equipment type

Overload block		Hydraulic power pack	
Flanged type	<input type="checkbox"/>	Adjutment of cut-off pressure	
Inline type	<input type="checkbox"/>	Manual	<input type="checkbox"/>
Inline type with non-return valves (unbalanced load)	<input type="checkbox"/>	Remotely controlled	<input type="checkbox"/>
		Nominal voltage U _N = _____ V _____ Hz	

Further information



HERION Systemtechnik GmbH

Untere Talstraße 65
71263 Weil der Stadt
Tel.: +49 (0) 7033/3018-0
Fax: +49 (0) 7033/3018-10
info@herion-systemtechnik.de
www.herion-systemtechnik.de

**A subsidiary of the Norgren and IMI group
of companies**

Distribution and Service

- in 75 countries through the Norgren service network

HERION Systemtechnik Sales Partners

China

ESTUN INDUSTRIAL AUTOMATION CO., LTS
155, Jiangjun Road, Jiangning Economical & Technical
Development Zone, Nanjing, 211100 P.R.C.
Tel.: +86-25-52785915
E-Mail: info@estun.com
www.estun.com

Germany

(PLZ-Gebiete 17-28, 30-32)

Kraeft GmbH Systemtechnik
Riedemannstr. 1
27572 Bremerhaven
Tel.: +49 (0)471/95208-0
E-Mail: info@kraeft-systemtechnik.de
www.kraeft-systemtechnik.de

Japan

Riken Optech Corporation
2-6-9, Higashi Ohi, Shinagawa-ku,
Tokyo 140-8533
Tel.: +81 3 34748602
E-Mail: contact@rikenoptech.com
www.rikenoptech.com

Korea

CHUNGWOO CO., LTD.
416-4 Dokjeongri
Janganmyun Hwaseongsi
Kyungkido, Korea
Tel.: +82 (0)31 351-5340
E-Mail: blueox2@unitel.co.kr
www.chungwooco.co.kr

Spain

EUROTECH SYSTEMS, S.L.
Av. Can LLuch, 25
08690 SANTA COLOMA DE CERVELLO
Tel.: +34 93 634 0101
E-Mail: eurotech@eurotechsys.com
www.eurotechsys.com

South Africa

Ernest Lowe ELCO
Pneumatic & Hydraulic Automation Solutions
6, Skew Road, Boksburg North 1459,
Gauteng, South Africa
Tel.: +27 (11) 898-6600
E-Mail: corporate@elco.co.za
www.elco.co.za

Taiwan

Full Life Trading Co., Ltd.
16F-4, No.2, Jian Ba Rd. Chung Ho City
Taipei County, Taiwan 23562
Tel.: +886-2-82261860
E-Mail: sales-dept@fulllifetrading.com
www.fulllifetrading.com

Turkey

Power Pnomatik Proses A. Ş
Necatibey Cad. No:44/2
Karaköy
Ystanbul 34420
Tel.: +90 212 2938870
E-Mail: info@powerpnomatik.com
www.powerpnomatik.com