

- > Port size: DN 15 ... 50, 1/2 ... 2 (ISO G/NPT)
- > Easy rebuilding into »normally open« or »double-acting« without tools
- > Optical position indicator is standard
- > Damped closing (Valves closes against flow direction)
- > Suitable for contaminated flow fluid
- > Suitable for vacuum up to max. 90%
- > Reversed flow direction optional
- > High flow rate
- > Option pressure actuated by external liquid fluid



Technical features

Medium:

Aggressive gases and liquids

Pilot fluid:

Neutral gases max. +60°C (+140°F)

Switching function:

Normally closed

Operation:

Pressure actuated by external fluid

Mounting position:

Optional

Flow direction:

Determined

Port size:

G1/2, G3/4, G1, G1 1/4, G1 1/2, G2 1/2 NPT, 3/4 NPT, 1 NPT, 1 1/4 NPT, 1 1/2 NPT, 2 NPT

Pilot connection:

G1/4 or 1/4 NPT

Operating pressure:

See table

Pilot pressure:

3,5 ... 10 bar (51 ... 145 psi)

Fluid temperature:

-10 ... +180°C (+14 ... +356°F)

Ambient temperature:

-10 ... +60°C (+14 ... +140°F)

Material:

Process fluid characteristics:

Body: Stainless steel (1.4581)

Seat seal: PTFE

Internal parts: Stainless steel

Spindle sealing: PTFE / FPM; self-adjustable

Pilot fluid characteristics:

Body: Polyamid 66 with glass fibre 30%

Seat Seals: NBR

Internal parts: Brass, Stainless steel, 1.8159, 1.1200

Technical data - standard models

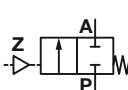
Symbol	Port size	Orifice (mm)	Flow kv value *1) (m³/h)	Operating pressure *2) (bar)	Weight (kg) *3)	Model *3)
	G1/2	15	4,8	0 ... 16 (25)	1,4	8452200.0000.00000
	1/2 NPT	15	4,8	0 ... 16 (25)	1,4	8453200.0000.00000
	G3/4	20	10	0 ... 10 (16)	1,5	8452300.0000.00000
	3/4 NPT	20	10	0 ... 10 (16)	1,5	8453300.0000.00000
	G1	25	14	0 ... 10	1,8	8452400.0000.00000
	1 NPT	25	14	0 ... 10	1,8	8453400.0000.00000
	G1 1/4	32	23	0 ... 7	2,4	8452500.0000.00000
	1 1/4 NPT	32	23	0 ... 7	2,4	8453500.0000.00000
	G1 1/2	40	30	0 ... 4,5	2,7	8452600.0000.00000
	1 1/2 NPT	40	30	0 ... 4,5	2,7	8453600.0000.00000
	G2	50	37	0 ... 3	3,9	8452700.0000.00000
	2 NPT	50	37	0 ... 3	3,9	8453700.0000.00000

*1) Cv-value (US) ≈ kv value x 1,2

*2) For gases and liquid fluids up to 600 mm²/s (cSt)

*3) Without pilot valve

Option selector

845****.0000.00000

Thread form	Substitute
ISO G	2
NPT	3
Port size	Substitute
1/2	2
3/4	3
1	4
1 1/4	5
1 1/2	6
2	7

Valve options	Substitute
Normally open (NO), closes with pilot pressure and opens with spring force (pilot pressure 1 ... 10 bar)	01
Double acting, 4/2 or 5/2-way-pilot valve required	08
Electrical position indicator with 2 micro-switches protection class IP 67, LED, 2 m cabel LifYY 2 x 0,25 qmm Type: NAMUR DIN EN 60947-5-6	23
NAMUR interface plate	50

Notes

for 3/2-way pilot valve 84660 / 84680

Material	Body Aluminium
Pilot fluid temperature	max. +60°C
Pilot pressure	1 ... 10 bar
Standard voltages	24 V d.c., 24 V a.c., 230 V a.c.

Notes

for 3/2-way pilot vale 97100 hole pattern NAMUR

Material	Body Aluminium elox
Pilot fluid temperature	-10 ... +50°C (+14 ... +122°F)
Pilot pressure	2 ... 8 bar
Standard voltages	24 V d.c., 24 V a.c., 230 V a.c.

Electrical Data

for 3/2-way pilot valve 84660 / 84680

Design acc. to	DIN VDE 0580
Voltage range	±10%
Duty cycle	100% ED
Protection class	EN 60529 IP65 with mounted socket
Socket	Form A acc. to DIN EN 175301-803 (included)
Technical data	See publication N/en 5.8.640

Electrical Data

for 3/2-way pilot valve 97100 hole pattern NAMUR

Design acc. to	DIN VDE 0580
Voltage range	±10%
Duty cycle	100% ED
Protection class	EN 60529 IP65 with mounted socket
Socket	Form A acc. to DIN EN 175301-803 (included)
Technical data	See publication N/en 5.4.372

Further versions on request!

Mounting accessories (NAMUR)

Interface plate NAMUR hole pattern for retrofit (Part-Number 1256566) consist of:
1x NAMUR-interface plate; 2x Adapter screw; 2x O-ring

Section View

G1/2 ... 2
1/2 ... 2 NPT

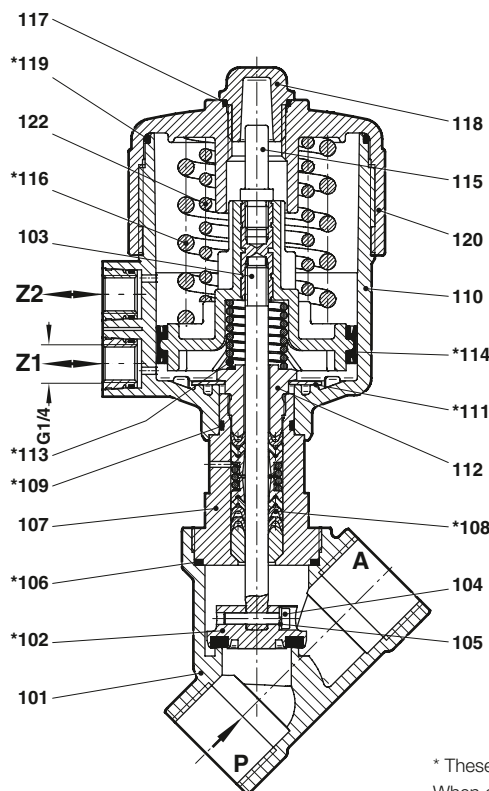

No.	Description
101	Valve body
*102	Valve plate
103	Valve spindle, complete
104	Cheese head cap screw
105	Spring washer
*106	Seal ring
107	Screw piece
*108	Seal packing
*109	O-ring
110	Control head housing cover, bottom part
*111	Cup spring
112	Screw piece
*113	Pressure spring
*114	Cylinder packing
115	Signal pin
*116	Pressure spring
*117	O-ring
118	Cover cap
*119	O-ring
120	Control head housing cover
122	Pressure spring

* These individual parts form a complete wearing unit.
When ordering spare parts please state Model No. and Series No.

Dimensions
G1/2 ... 2
1/2 ... 2 NPT

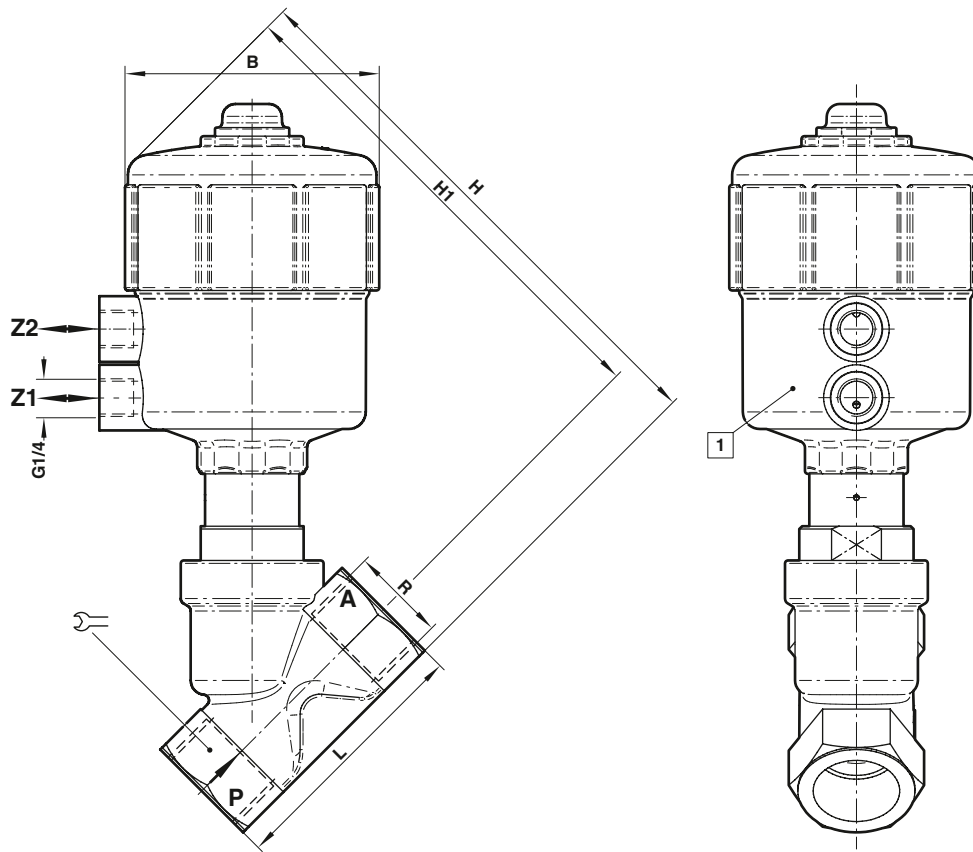
 Dimensions in mm
 Projection/First angle

1 Actuator may be rotated 360°

Port size	B	H	H1	L		Model
G1/2	89,5	177,5	164	65	27	8452200.0000.00000
1/2 NPT	89,5	177,5	164	65	27	8453200.0000.00000
G3/4	89,5	184	168	75	32	8452300.0000.00000
3/4 NPT	89,5	184	168	75	32	8453300.0000.00000
G1	89,5	194,5	174	90	41	8452400.0000.00000
1 NPT	89,5	194,5	174	90	41	8453400.0000.00000
G1 1/4	89,5	209,5	184,5	110	50	8452500.0000.00000
1 1/4 NPT	89,5	209,5	184,5	110	50	8453500.0000.00000
G1 1/2	89,5	208,5	186	120	55	8452600.0000.00000
1 1/2 NPT	89,5	208,5	186	120	55	8453600.0000.00000
G2	89,5	229,5	194,5	150	70	8452700.0000.00000
2 NPT	89,5	229,5	194,5	150	70	8453700.0000.00000

Note to Pressure Equipment Directive (PED):

The valves of this series, including the connection size DN 25 (G1), are according to Art. 4 § 3 of the Pressure Equipment Directive (PED) 2014/68/EU (97/23/EG). This means interpretation and production are in accordance to engineers practice wellknown in the member countries. The CE-sign at the valve refers not to the PED. Thus the declaration of conformity is not longer applicable for this directive.

For valves > DN 25 (G1) Art. 3 § (1) No.1.4 applies:

The basic requirements of the Enclosure I of the PED must be fulfilled. The CE-sign at the valve includes the PED. A certificate of conformity of this directive will be available on request.

Note to Electromagnetic Compatibility Guideline (EMC):

The valves shall be provided with an electrical circuit which ensures the limits of the harmonised standards EN 61000-6-3 and EN 61000-6-1 are observed, and hence the requirements of the Electromagnetic Compatibility Guideline 2014/30/EU (2004/108/EG) satisfied.