

- > Port size: DN 20 ... 40, G3/4 ... 1 1/2
- > High flow rate
- > All internal components captive
- > Clear, compact design
- > Solenoid interchangeable without tools (*Twist-on®*)
- > Integrated silencer
- > One-piece diaphragm

Twist-on®
Stainless Steel



Technical features

Medium:

Air

Switching function:

Normally closed

Flow direction:

Determined

Mounting position:

Optional, preferably solenoid vertical on top

Port size:

G3/4, G1, G1 1/2

Operating pressure:

0,4 ... 8 bar (5,8 ... 116 psi)

Dusty gas temperature:

-20° ... +85°C (-4° ... +185°F)

Cleaning gas temperature:

-40° ... +85°C (-40° ... +185°F)

Ambient temperature:

-20° ... +85°C (-4° ... +185°F)

Material:

Body: Stainless steel 1.4408

Seat seal: TPE

Internal parts: TPU

Technical data - standard models

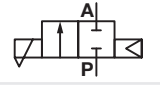
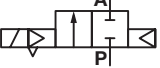
Symbol	Port size	Orifice (mm)	Valve length (mm)	Flow kv value *1) (m³/h)	Operating pressure (bar)	Weight (kg)	Model
	G3/4	20	95	18	0,4 ... 8	0,92	8332300.8171.xxxxx
	G1	25	95	22	0,4 ... 8	1,01	8332400.8171.xxxxx
	G1 1/2	40	135	59	0,4 ... 8	3,11	8332600.8171.xxxxx

xxxxx Please insert voltage and frequency codes

*1) Cv-value (US) ≈ kv value x 1,2

Option selector

8332***.8171.*****

Port size	Substitute
3/4	3
1	4
1 1/2	6
Valve options	Substitute
Flange version without valve body	54
Dusty gas temperature version -20 ... +100°C, Seat seal TPE, Ambient temperature -40 ... +85°C (-40 ... +185°F), Cleaning gas temperature -20 ... +85°C (-4 ... +185°F)	62
Dusty gas temperature version -20 ... +140°C, Seat seal TPE, Ambient temperature -40 ... +85°C (-40 ... +185°F), Cleaning gas temperature -20 ... +85°C (-4 ... +185°F)	63
Low temperature version only for solenoid 8xxx/9150, -45 ... +140°C Seat seal TPE, Ambient temperature -40 ... +85°C (-40 ... +185°F), Cleaning gas temperature -20 ... +85°C (-4 ... +185°F)	71

Frequency	Substitute
See table frequency codes	xx
Voltage	Substitute
See Voltage codes	xxx

Standard solenoid systems

Code Voltage	Code Frequency	Voltage	Frequency	Power consumption Inrush	Holding
024	00	24 V d.c.	-	12 W	12 W
024	50	24 V a.c.	50 Hz	23 VA	16 VA
110	50	110 V a.c.	50 Hz	23 VA	16 VA
120	60	120 V a.c.	60 Hz	23 VA	16 VA
230	50	230 V a.c.	50 Hz	23 VA	16 VA

*1)  US coil only

Electrical details for all solenoid systems

Design	DIN VDE 0580
Voltage range	±10%
Duty cycle	100% ED
Protection class	EN 60529 IP65
Socket	Form A acc. to DIN EN 175301-803 (included)

According to DIN VDE 0580 at a solenoid temperature of +20°C. At operating state temperature the input power of a coil decreases by up to ca. 30% due to physical reasons.



Additional solenoid systems (available since April 2018)

ATEX category	ATEX protection class	IP protection class	So-lenoid	Standard voltages	Old variant
II 2G II 2D	Ex eb mb IIC T6...T4 Gb Ex tb IIIC T130°C Db	IP66	42xx	24 V d.c., 110 V a.c., / 230 V a.c.	
II 2G II 2G II 2D	Ex d mb IIC T6/T5/T4 Gb Ex e mb IIC T6/T5/T4 Gb Ex tb IIIC T130°C/T95°C/ T80°C Db	IP66	46xx	24 V d.c., 110 V a.c., / 230 V a.c.	
II 3G II 3D	Ex nA IIB T4 Gc Ex tc IIIB T130°C Dc	IP65	8176	24 V d.c., 110 V a.c., / 230 V a.c.	
II 2G II 2D	Ex eb mb IIC T4 Gb Ex mb tb IIIB T135°C Db	IP66	6176	24 V d.c., 110 V a.c., / 230 V a.c.	8186

Attention!

The conditions imposed on the Ex approvals lead to reduction of the permissible standard temperature ranges in the cases of explosion protected solenoids.

Additional solenoid systems

Option	Solenoid	Standard voltages
Solenoid version for low temperature -40°C	9151	24 V d.c., 110 V a.c., 230 V a.c.

Section View

G3/4 ... 1
3/4 ... 1 NPT

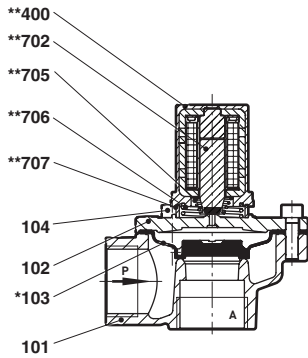

G1 1/2
1 1/2 NPT

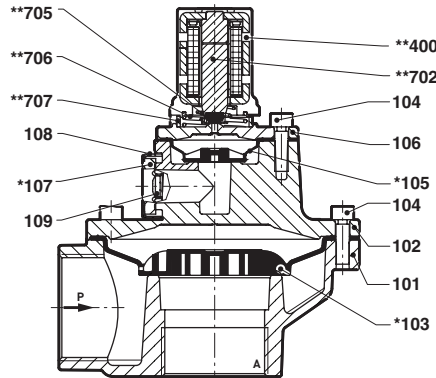

No.	Description
101	Valve body
102	Valve cover
*103	Diaphragm
104	Socket head cap screw
*105	Diaphragm
106	Valve cover
*107	Silencer
108	Silencer housing
109	Socket head cap screw
**400	Solenoid
**702	Core
**705	Pressure spring
**706	Pressure spring
**707	Silencer
1400	Socket (included)

* These individual parts form a complete wearing unit.
When ordering spare parts please state Cat No and Series No.
** Solenoid complete wearing unit, e.g. 8298000.8170.XXXXX for a solenoid 8170

Dimensions

G3/4 ... 1

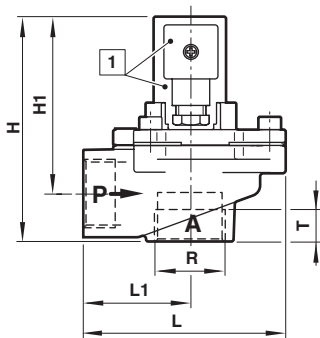

G1 1/2

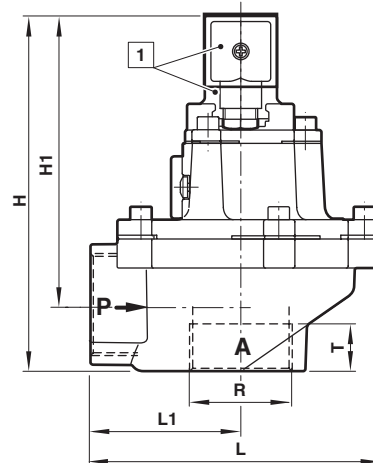

Dimensions in mm
Projection/First angle

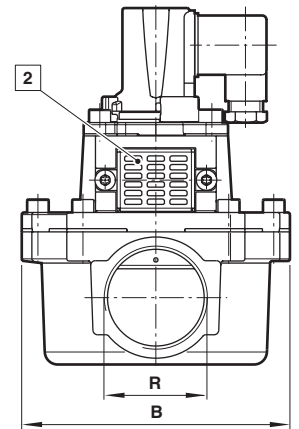

- 1 Solenoid rotatable 3 x 120°
Socket tumbable 4 x 90°
(Socket included)
- 2 Silencer

Port size R	B	H	H1	L	L1	T	Model
G3/4	80	105,5	83	95	50	18	8332300.8171.xxxxx
G1	80	105,5	83	95	50	18	8332400.8171.xxxxx
G1 1/2	124,5	166	136	135	70	22	8332600.8171.xxxxx

Note to Pressure Equipment Directive (PED):

The valves of this series are according to clause 4 § 3 of the Pressure Equipment Directive (PED) 2014/68/EU. This means interpretation and production are in accordance to engineers practice wellknown in the member countries. The CE-sign at the valve refers not to the PED. Thus the declaration of conformity is not longer applicable for this directive.

Note to Electromagnetic Compatibility Guideline (EEC):

The valves shall be provided with an electrical circuit which ensures the limits of the harmonised standards EN 61000-6-3 and EN 61000-6-1 are observed, and hence the requirements of the Electromagnetic Compatibility Guideline (2014/30/EU) satisfied.